



EASY CLEAN SYSTEM

“Sistema Easy Clean”: piatto inclinabile per una rapida pulizia della zona di taglio..

“Easy Clean System”: special meat plate that can be opened for an easier cleaning..

CARATTERISTICHE

- Basamento pressofuso in alluminio laccato con doppia mano di vernice più trasparente uso alimentare.
- Lama professionale di terza generazione, temperata, rettificata e cromata al cromo duro.
- Pressamerce in lega di alluminio anodizzato.
- Motore professionale ad induzione asincrono autoventilato.
- Coprilama e piatto in alluminio fuso protetto con ossidazione anodica.
- Vela in alluminio fuso protetto con ossidazione anodica.
- Manopola graduata per la regolazione dello spessore di taglio (fino a 14÷16 mm).
- Anello fisso di protezione della lama.
- Albero portalama montato su doppio cuscinetto a sfere.

FEATURES

- Die-cast casing in laquered aluminium with two coats of paint and one of transparent for contact with food.
- Professional tempered ground hard chromium-plated third generation blade.
- Food holder arm in anodized aluminium.
- Professional ventilated motor.
- Blade cover and food tray in die-cast aluminium protected by an anodic oxidation.
- Sail-shaped rest in die-cast aluminium protected by an anodized oxidation.
- Graduated knob for adjust slicing thickness (up to 14÷16 mm).
- Fixed blade protection ring.
- Shaft holding the blade mounted on a double ball-bearing.



Affilatoio fisso.
Fixed sharpener.



Pressamerce in lega di alluminio anodizzato.
Food-holder arm in anodized aluminium.

DIMENSIONI - DIMENSIONS

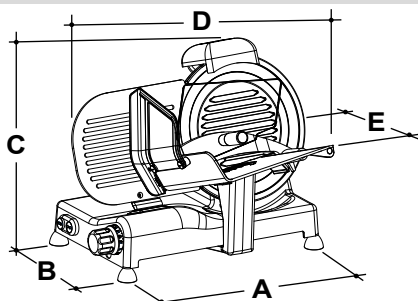

A	B	C	D	E
mm	mm	mm	mm	mm
440	290	460	605	525

A e B = interasse piedini
A and B = wheelbase between feet

SERIE LUXURY	Diametro lama Blade diameter	Potenza motore Power	Capacità di taglio Cutting capacity	Ø taglio Ø cutting	Corsa carrello Trolley run	Peso netto Net weight	Imballo Packing
MOD	Ø mm	Watt	±5 mm	±5 mm	mm	Kg	cm
300 G-ES CEV	300	180	240 x 195	Ø 205	270	24	53 x 63 x 48 (0,16m³)

Via Giovanni XXIII, 11 - 22072 Cermenate (CO) Italy - Tel +39 031.722.819 - Fax +39 031.722.825 - info@rgv.it

www.rgv.it